



Mechanical Safety Chucks

Answer for your heavy load roll shaft support wind and unwind applications



Jeyson's MSCF & MSCP Series C-Type Mechanical Safety Chucks

Jeysons Industries is in the business of manufacturing highly reliable and technically superior industrial clutches & brakes, safety chucks and other power transmission products; providing strong engineering and technical support to clients interested in increasing their competitiveness and productivity in the ever-changing global market.

Our vision

To continually provide the best products & world class support to our customers by applying the highest standards of business processes which add value to our customers, suppliers and employees.

Our mission

To become India's leading **Manufacturer of Industrial Clutches & Brakes** by providing world-class quality and cost effective products to the world market. We will achieve this by offering an unparalleled level of service and commitment, which not only meets but exceeds our customer's expectations and requirements.

Through partnerships we will develop **Our people, Processes and Technology** to excel in business performance.

Our philosophy

At Jeysons, our philosophy is KISS (Keep It Simple Systems); we design and manufacture technically superior and competitively priced products. Our products are easy to use, have minimal downtime and lower operating & maintenance costs, while customers benefit from the highest level of customer satisfaction from us.

About us

Jeysons Industries launched its manufacturing operations in the year 2003. Suitably armed with an independent 4500 sq. ft. factory building, we work with a team of highly skilled professionals with 30 years experience in the field of manufacturing precision engineering products and components for some of the most critical industries of the world. Our quality control department too is at par with international standards where all instruments, gauges, jig & fixtures and machines are periodically calibrated. Testing, Identification and Traceability from Raw Material to Finished Products are standard norms followed by us. Even bought out components are identified and tracked in our well equipped systems.

Our products are field proven; 90% of our sales are from repeat customers and our products are running in 24x7 environments without breakdown or need for maintenance for years. [Our standard policy for all products is one year replacement warranty and 60 days no questions ask money back guarantee.](#)

Mechanical Safety Chucks

Jeysons MSCF and MSCP lines of rugged safety chucks provide roll shaft support and torque transmission at a low cost. The maintenance-free design ensures optimal performance throughout the life of each safety chuck. Jeyson's units safe-guard your equipment securing the roll shaft in place during any wind unwind operation. Our safety chucks will only open with the socket in the upright position.

Available in either foot/pedestal or flange mounting, these safety chucks complement Jeysons dependable line of tension control brakes and clutches, offering you a complete package with seamless installation and operation.

- Redundant safety mechanisms securely lock shaft in place
- Long, maintenance-free life
- Durable construction
- Cast iron housing
- Chrome plated, steel handwheel
- Shaft hardened to 30-35 HRC, protecting the roll shafts. 58-60 HRC hardened shaft available on request.
- Available in ready-to-assemble brake packages
- Free turning precision ball bearings
- Shaft extensions with keyway
- Foot/Pedestal or flange mounting
- Inch / Metric size sockets available as standard

Applications

- Converting
- Printing
- Rubber
- Film
- Foil
- Paper
- Plastics
- Textiles
- Rope/Cable/Wire



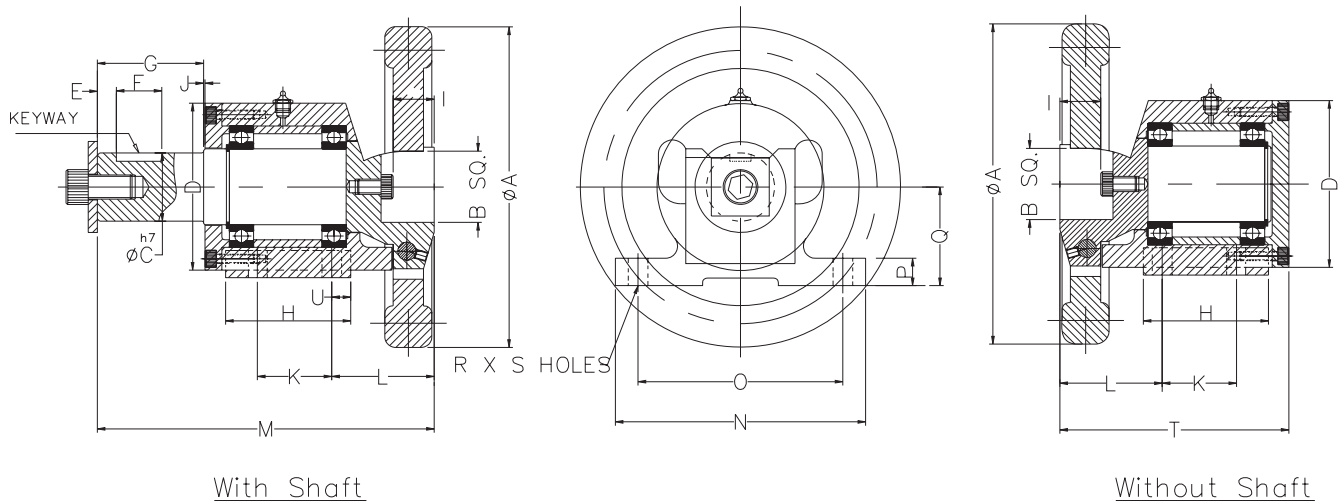

With Shaft

Without Shaft

MODEL	Type	Pedestal (Foot) Mounted Safety Chuck - MSCP						
	Size	14-20	19-25	22-30	40-50	50-60	60-80	80-100
TECHNICAL	Max. Beam Weight (Kg)	150	400	800	2000	2800	6000	10000
	Torque (Nm)	40	120	180	895	1100	1850	8000
DIAMETER	Square Size (Min)	14	19	22	40	45	60	80
	Square Size (Max)	20	25	30	50	60	80	100
	ØA	128	140	160	211	255	320	360
	ØC	16	19	28.575	45	55	70	85
LENGTH	ØD	52	75	90	110	130	185	200
	Keyway	5 x 3.0	6 x 3.5	6 x 3.0	14 x 5.5	16 x 6.0	20 x 7.5	22 x 9.0
	E	5	5	12.5	12.5	12.5	12.5	12.5
	F	20	35	30	30	80	100	110
	G	32	45	70	70	110	133	143
	H	45	50	60	80	110	130	165
	I	12	19	17	25	30	35	45
	J	1.0	1.0	1.0	1.0	2.0	3.0	3.0
	K	-	-	-	55	70	80	105
	L	46.5	70	46	67.5	78	90	106
	M	105	156	201	222	310	376	411
	N	120	120	135	165	200	250	300
	O	95	100	105	135	160	215	240
	P	10	18	20	18	24	28	32
Q	50	50	65	60	75	90	115	
	R-S HOLES	2 - Ø9 hole	2 - Ø9.5 hole	2 - Ø13 hole	4 - Ø13 hole	4 - Ø18 hole	4 - Ø18 hole	4 - Ø22 hole
	T	73	111	130	151	200	240	265
	U	22.5	25	30	12.5	20	25	30

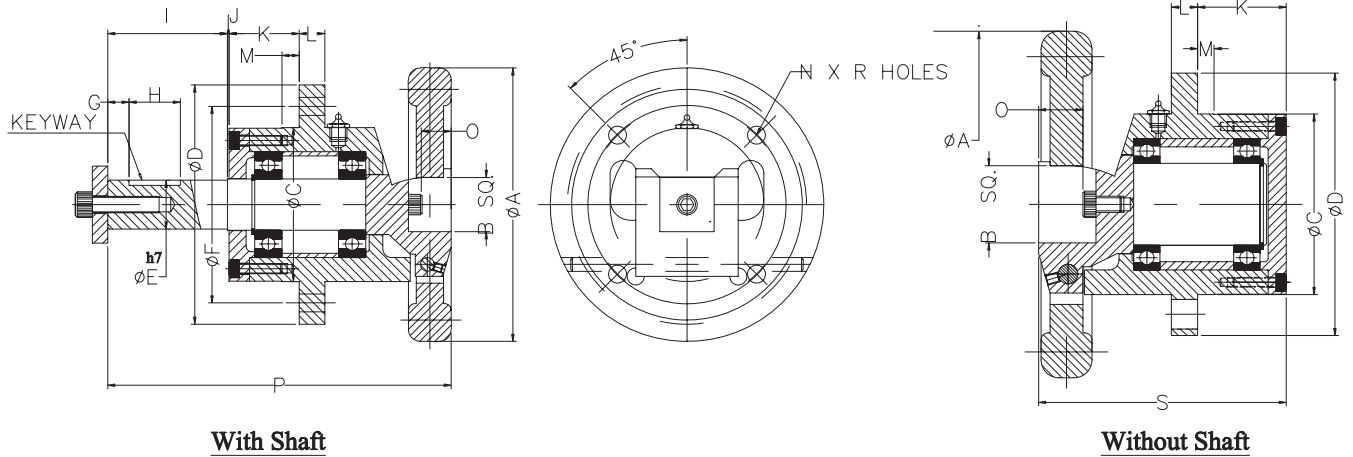

With Shaft

Without Shaft

MODEL	Type	Flange Mounted Safety Chuck - MSCF						
	Size	14-20	19-25	22-30	40-50	50-60	60-80	80-100
TECHNICAL	Max. Beam Weight (Kg)	150	400	800	2000	2800	6000	10000
	Torque (Nm)	40	120	180	875	1100	1850	8000
DIAMETER	Square Size (Min)	14	19	22	40	45	60	80
	Square Size (Max)	20	25	30	50	60	80	100
	ØA	128	140	160	211	255	320	360
	ØC	52	75	90	110	130	185	200
	ØD	76	110	140	160	210	260	300
	ØE	16	19	28.575	45	55	75	110
	ØF	64	92	115	134	170	220	250
	Keyway	5 x 3.0	6 x 3.5	8 x 4.0	14 x 5.50	16 x 6.0	20 x 7.5	22 x 9.0
LENGTH	G	5	5	15	12.5	12.5	12.5	12.5
	H	20	35	40	30	80	100	110
	I	32	45	70	70	110	133	143
	J	1	1	1	1	2	3	3
	K	21	29	41	54	68	76	82
	L	-	12	15	16	22	27	32
	M	-	-	10	10	15	15	20
	O	12	19	17	25	30	35	45
	P	105	156	201	222	310	376	411
	S	72	111	130	151	200	240	265
	N-R HOLES	4 x M6	4 - Ø9 hole	4 - Ø11 hole	4 - Ø18 hole	4 - Ø18 hole	4 - Ø18 hole	4 - Ø22 hole

